



LEI LING TECHNOLOGY CO., LTD

Find a way to live with nature
Committed to the development of new energy

Company name: Lei Ling Technology Co., Ltd

Address: 12th Floor, Building B2, Gaosheng West Lake
Zhigu Industrial Park, No. 40, Hongling 3rd Road, Shuikou Street,
Huicheng District, Huizhou City, Guangdong, China

Site: <https://urayzero.com>

Email: service@urayzero.com

Company Profile

Founded in Huizhou city, China in 2022, Leiling Technology Co., Ltd. is a science and technology company, specialized in the R&D, production and sales of new energy products, which mainly covering solar modules, solar inverters, solar pumping inverter storage batteries, and providing technical support of complete set of photovoltaic storage system solutions etc.

Since its establishment, the company has been focusing on products development, marketing layout and customer service.

Lei ling Technology has been continuously optimising and innovating in the areas of R&D team reinforcement, production capacity layout optimisation, supply chain stabilisation and marketing team globalisation. Our company has developed wide range of sales channels around the world with Huizhou city as the centre, and the products have been marketed to many countries and regions in Europe, Asia Pacific, Middle East and Africa, etc. we are committed to providing our customers with advanced and reliable clean energy solutions in order to respond quickly to the changing market,

Lei ling Technology stick to the core concept of "quality-oriented, technological innovation service first, win-win cooperation" to promote the global development of clean energy and provide customers with high-quality products and services.

Enterprise strength

We have a rich R&D team and a complete production organizational structure including R&D department, production department, quality department and other core departments. The R&D department is responsible for product development and design, the production department is responsible for product manufacturing and assembly, and the quality department is responsible for product quality control and inspection. Close cooperation between the departments is maintained to ensure the smooth progress of products from R&D to production.

In the future development, we will pay more attention to sustainable development, environmental protection and energy conservation. Through the introduction of using the renewable energy to help people save the living cost, to realize the low carbon target, to make more people to use the green energy. Let's work together to get our living world to be more green, clean and shiny.

Authentication certificate



Solar Pumping Inverter



LWS 220V50/60Hz 1 Phases

Without AC Bypass Input Series
LWS 1500SL / LWS 2200SL

With AC (Grid/DG) Bypass Input Series
LWS 1500SLA / LWS 2200SLA



LWS 380V50/60Hz 3 Phases

Without AC Bypass Input Series
LWS 3000 / LWS 4000 / LWS 5500 / LWS 7500
LWS 9200 / LWS 11000/ LWS 13000/ LWS 15000
LWS 18500/ LWS 22000/ LWS 26000/ LWS 30000

With AC (Grid/DG) Bypass Input Series
LWS 3000A / LWS 4000A / LWS 5500A / LWS 7500A
LWS 9200A / LWS 11000A/ LWS 13000A/ LWS 15000A
LWS18500A/ LWS 22000A/ LWS 26000A/ LWS 30000A



LWS 380V50/60Hz 3 Phases

Without AC Bypass Input Series
LWS 37000/ LWS 45000/ LWS 55000

With AC (Grid/DG) Bypass Input Series
LWS 37000A/ LWS 45000A/ LWS 55000A



Advantage of Solar Pumping System

- ◆ Reliable: solar power supplies rarely use moving parts, work reliably
- ◆ Safe, no noise, no other pollution. Does not produce any solid, liquid and gaseous harmful substances, absolutely environmentally friendly
- ◆ Simple installation and maintenance, low operating cost, suitable for unattended and other advantages, especially for its high reliability
- ◆ Good compatibility, solar power generation can be used in conjunction with other energy sources, and the solar power system can be easily increased capacity according to needs
- ◆ The degree of standardization is high, and the solar panels can be connected in series and parallel to meet the needs of different electricity consumption, with strong versatility
- ◆ Solar energy is everywhere with a wide range of applications

Solar water pumping system utilizes the long-lasting energy from the sun, works at sunrise, and earns income every day, without personnel supervision, no fossil energy, no government grid, independent operation, safe and reliable. It can be used with drip irrigation, sprinkler irrigation, seepage irrigation and other irrigation facilities to effectively solve the problem of arable land irrigation, increase production, save water and energy, and greatly reduce the input cost of traditional energy and electricity. Therefore, it has become the most effective way to use clean energy to replace fossil energy, and has also become a new energy and new technology application product for comprehensive solutions to the global "food problem" and "energy problem".

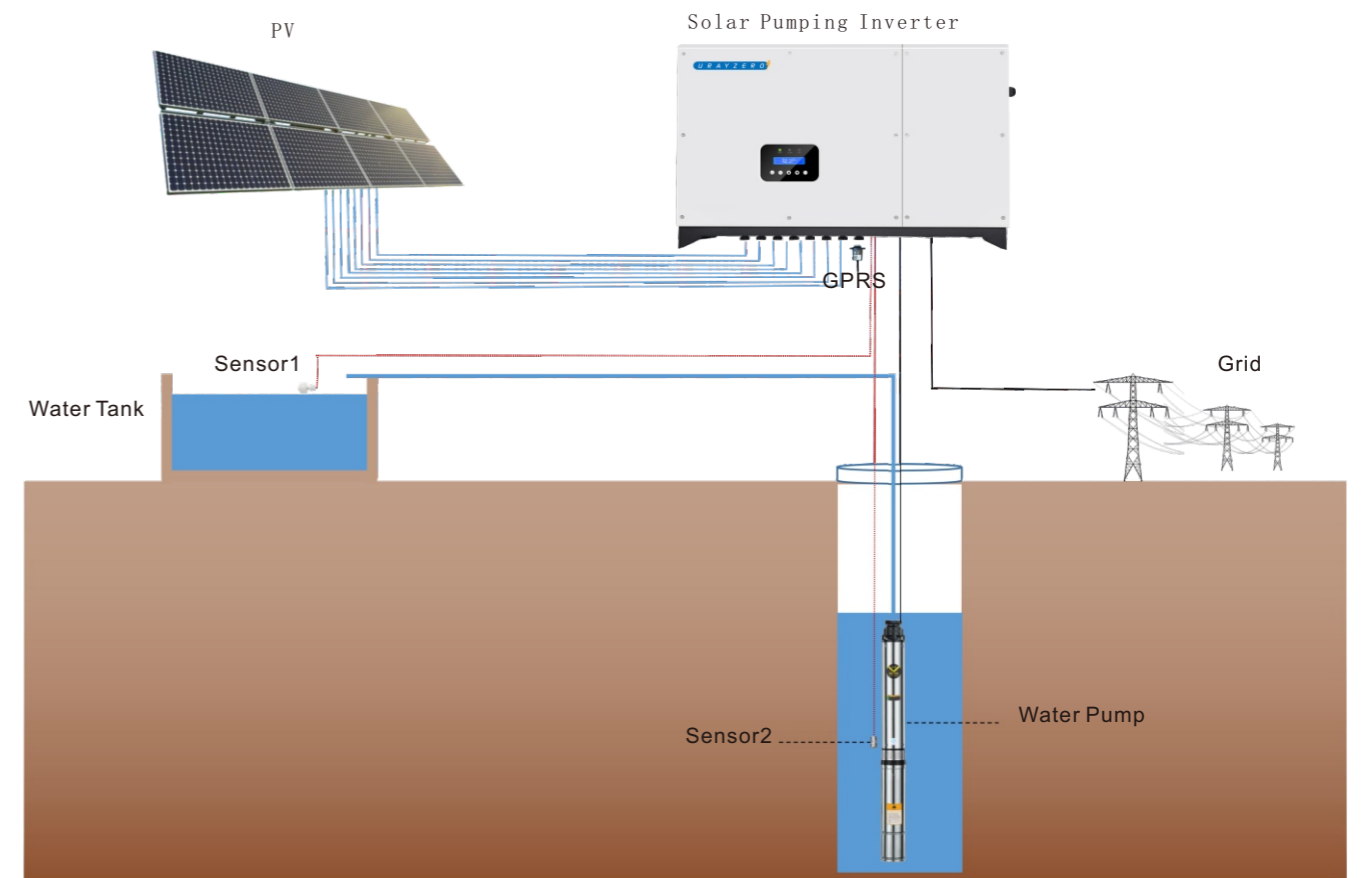



Features

- IP65
- Aluminum alloy shell
- LCD screen
- AC/DC switching
- Remote monitoring
- Compact design

System Applications

1.5kw - 2.2kw single phase solar pumping inverter for residential and shallow wells & deep well, as long as the water pump is running by AC motor.



	LWS 1500SL	LWS 1500SLA	LWS 2200SL	LWS 2200SLA
MPPT number	1	1	1	1
Max. input strings	1	1	1	1
Start voltage (V)	80	80	80	80
Max. input current (A)	13	13	15	15
Max. input voltage (V)	500	500	500	500
MPPT voltage range (V)	200 - 400	200 - 400	270 - 400	270 - 400

	LWS 1500SL	LWS 1500SLA	LWS 2200SL	LWS 2200SLA
Input voltage range (V)	-	220±15%	-	220±15%
Input frequency range (Hz)	-	50/60±5%	-	50/60±5%

	LWS 1500SL	LWS 1500SLA	LWS 2200SL	LWS 2200SLA
Rated output power (W)	1.5	1.5	2.2	2.2
Rated voltage (V)	220	220	220	220
Output voltage range (V)	0 - 220	0 - 220	0 - 220	0 - 220
Output frequency (Hz)	0 - 50/60	0 - 50/60	0 - 50/60	0 - 50/60
Max. output current (A)	10	10	14	14

	LWS 1500SL	LWS 1500SLA	LWS 2200SL	LWS 2200SLA
Display screen	LCD			
Communication port	RS485/CAN/GPRS			
Protection level	IP65			
Operating altitude (m)	<6000 (>3000 derating)			
Cooling concept	Natural cooling			
Operating temperature range (°C)	-25°C~+60°C			
Dimension (L*W*H mm)	395*355*160	395*355*160	395*355*160	395*355*160
Net weight (kg)	10	10	10	10
Packing (L*W*H mm)	495*420*245	495*420*245	495*420*245	495*420*245
Gross weight (Kg)	12	12	12	12

	LWS 1500SL	LWS 1500SLA	LWS 2200SL	LWS 2200SLA
Water pump type	AC pump	AC pump	AC pump	AC pump
Rated voltage (V)	220	220	220	220
Frequency (Hz)	50	50	50	50
Inverter power (W)	1500	1500	2200	2200
Max. input current (A)	10	10	14	14
Applicable motor power	1.5kW/2HP	1.5kW/2HP	2.2kW/3HP	2.2kW/3HP



Features

- IP65
- Aluminum alloy shell
- LCD screen
- AC/DC switching
- Remote monitoring
- Compact design

System Applications

3kw - 11kw three phase solar pumping inverter for residential and shallow Wells&deep well, as long as the water pump is running by AC motor.

13K-30K solar pumping inverter used for household, deep well, medium or large irrigation project, scope of application is relatively wide

Block Diagram

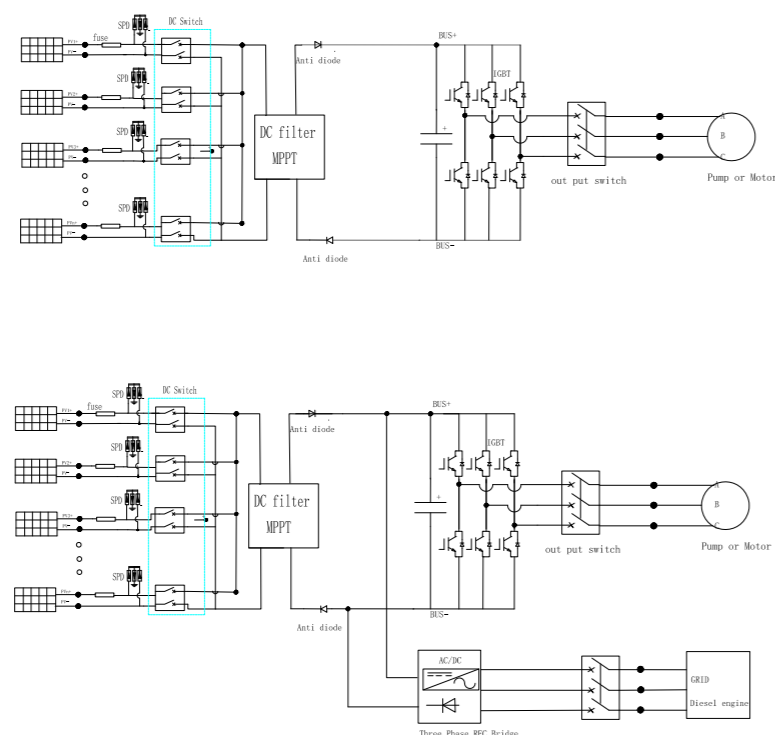

LWS 3000/3000A LWS 4000/4000A LWS 5500/5500A LWS 7500/7500A LWS 9200/9200A

DC Input

MPPT number	1	1	1	1	1
Max. input strings	2	2	2	3	3
Start voltage (V)	250	250	250	250	250
Max. input current (A)	9	11	12	19	22
Max. input voltage (V)	900	900	900	900	900
MPPT voltage range (V)	450 - 750	450 - 750	450 - 750	450 - 750	450 - 750

AC Output

Rated output power (W)	3000	4000	5500	7500	9200
Rated voltage (V)	380	380	380	380	380
Output voltage range (V)	0 - 440	0 - 440	0 - 440	0 - 440	0 - 440
Output frequency (Hz)	0 - 50/60	0 - 50/60	0 - 50/60	0 - 50/60	0 - 50/60
Max. output current (A)	8	10	11	18	21

General Data

Display screen	LCD				
Communication port	RS485/CAN/GPRS				
Protection level	IP65				
Operating altitude (m)	<6000 (>3000 derating)				
Cooling concept	Natural cooling				
Operating temperature range (°C)	-25°C~+60°C				
Dimension (L*W*H mm)	395*355*160	395*355*160	395*355*160	465*365*168	465*365*168
Net weight (kg)	11	11	11	13	13
Packing (L*W*H mm)	495*420*245	495*420*245	495*420*245	567*440*250	567*440*250
Gross weight (Kg)	13	13	13	15	15

Recommended Water Pump

Water pump type	AC pump	AC pump	AC pump	AC pump	AC pump
Rated voltage (V)	380	380	380	380	380
Frequency (Hz)	50	50	50	50	50
Inverter power (W)	3000	4000	5500	7500	9200
Max. input current (A)	8	10	11	18	21
Applicable motor power	3kW/4HP	4kW/5.5HP	5.5kW/7.5HP	7.5kW/10HP	9.2kW/12.5HP

AC Input

LWS 3000A LWS 4000A LWS 5500A LWS 7500A LWS 9200A

Input voltage range (V)	380±15%	380±15%	380±15%	380±15%	380±15%
Input frequency range (Hz)	50/60±5%	50/60±5%	50/60±5%	50/60±5%	50/60±5%

Datasheet

LWS 11000/11000A LWS 13000/13000A LWS 15000/15000A LWS 18500/18500A LWS 22000/22000A

DC Input

	LWS 11000/11000A	LWS 13000/13000A	LWS 15000/15000A	LWS 18500/18500A	LWS 22000/22000A
MPPT number	1	1	1	1	1
Max. input strings	3	4	4	6	6
Start voltage (V)	250	250	250	250	250
Max. input current (A)	24	31	32	38	46
Max. input voltage (V)	900	900	900	900	900
MPPT voltage range (V)	450 - 750	450 - 750	450 - 750	450 - 750	450 - 750

AC Output

	LWS 11000	LWS 13000	LWS 15000	LWS 18500	LWS 22000
Rated output power (W)	11000	13000	15000	18500	22000
Rated voltage (V)	380	380	380	380	380
Output voltage range (V)	0 - 440	0 - 440	0 - 440	0 - 440	0 - 440
Output frequency (Hz)	0 - 50/60	0 - 50/60	0 - 50/60	0 - 50/60	0 - 50/60
Max. output current (A)	24	28	30	39	45

General Data

Display screen	LCD				
Communication port	RS485/CAN/GPRS				
Protection level	IP65				
Operating altitude (m)	<6000(>3000 derating)				
Cooling concept	Smart Fan Cooling				
Operating temperature range (°C)	-25°C~+60°C				
Dimension (L*W*H mm)	465*365*168	505*415*190	505*415*190	505*415*190	505*415*190
Net weight (kg)	14	20	20.5	22	22
Packing (L*W*H mm)	567*440*250	586*512*280	586*512*280	586*512*280	586*512*280
Gross weight (kg)	16	23	23.5	25	25

Recommended Water Pump

Water pump type	AC pump	AC pump	AC pump	AC pump	AC pump
Rated voltage (V)	380	380	380	380	380
Frequency (Hz)	50	50	50	50	50
Inverter power (W)	11000	13000	15000	18500	22000
Max. input current (A)	24	28	30	39	45
Applicable motor power	11kW/15HP	13kW/17.5HP	15kW/20HP	18.5kW/25HP	22kW/30HP

LWS 11000A LWS 13000A LWS 15000A LWS 18500A LWS 22000A

AC Input

Input voltage range (V)	380±15%	380±15%	380±15%	380±15%	380±15%
Input frequency range (Hz)	50/60±5%	50/60±5%	50/60±5%	50/60±5%	50/60±5%

Datasheet

LWS 26000/26000A LWS 30000/30000A

DC Input

	LWS 26000/26000A	LWS 30000/30000A
MPPT number	1	1
Max. input strings	6	6
Start voltage (V)	250	250
Max. input current (A)	53	64
Max. input voltage (V)	900	900
MPPT voltage range (V)	450 - 750	450 - 750

AC Output

	LWS 26000	LWS 30000
Rated output power (W)	26000	30000
Rated voltage (V)	380	380
Output voltage range (V)	0 - 440	0 - 440
Output frequency (Hz)	0 - 50/60	0 - 50/60
Max. output current (A)	50	60

General Data

Display screen	LCD	
Communication port	RS485/CAN/GPRS	
Protection level	IP65	
Operating altitude (m)	<6000(>3000 derating)	
Cooling concept	Smart Fan Cooling	
Operating temperature range (°C)	-25°C~+60°C	
Dimension (L*W*H mm)	520*41*190	520*415*190
Net weight (kg)	22	22
Packing (L*W*H mm)	586*512*280	586*512*280
Gross weight (kg)	25	25

Recommended Water Pump

Water pump type	AC pump	AC pump
Rated voltage (V)	380	380
Frequency (Hz)	50	50
Inverter power (W)	26000	30000
Max. input current (A)	50	60
Applicable motor power	26kW/35HP	30kW/40HP

LWS 26000A LWS 30000A

AC Input

Input voltage range (V)	380±15%	380±15%
Input frequency range (Hz)	50/60±5%	50/60±5%



Features

- IP65
- Aluminum alloy shell
- LCD screen
- AC/DC switching
- Remote monitoring
- Compact design

System Applications

37kw - 55kw solar pumping inverter for commercial&industrial and deep Wells,as long as the water pump is running by AC motor.



LWS 37000/37000A LWS 45000/45000A LWS 55000/55000A

DC Input

MPPT number	1	1	1
Max. input strings	8	8	8
Start voltage (V)	250	250	250
Max. input current (A)	78	108	114
Max. input voltage (V)	900	900	900
MPPT voltage range (V)	450 - 750	450 - 750	450 - 750

AC Output

Rated output power (W)	37000	45000	55000
Rated voltage (V)	380	380	380
Output voltage range (V)	0 - 440	0 - 440	0 - 440
Output frequency (Hz)	0 - 50/60	0 - 50/60	0 - 50/60
Max. output current (A)	75	91	112

General Data

Display screen	LCD		
Communication port	RS485/CAN/GPRS		
Protection level	IP65		
Operating altitude (m)	<6000(>3000 derating)		
Cooling concept	Smart Fan Cooling		
Operating temperature range (°C)	-25°C~+60°C		
Dimension (L*W*H mm)	697*400*240	697*400*240	697*400*240
Net weight (kgs)	32	32	32
Packing (L*W*H mm)	750*530*315	750*530*315	750*530*315
Gross weight (kg)	35	35	35

Recommended Water Pump

Water pump type	AC pump	AC pump	AC pump
Rated voltage (V)	380	380	380
Frequency (Hz)	50	50	50
Inverter power (W)	37000	45000	55000
Max. input current (A)	75	91	112
Applicable motor power	37kW/50HP	45kW/60HP	55kW/75HP

LWS 37000A LWS 45000A LWS 55000A

AC Input

Input voltage range (V)	380±15%	380±15%	380±15%
Input frequency range (Hz)	50/60±5%	50/60±5%	50/60±5%

Three Phase Solar Pumping Inverter Features

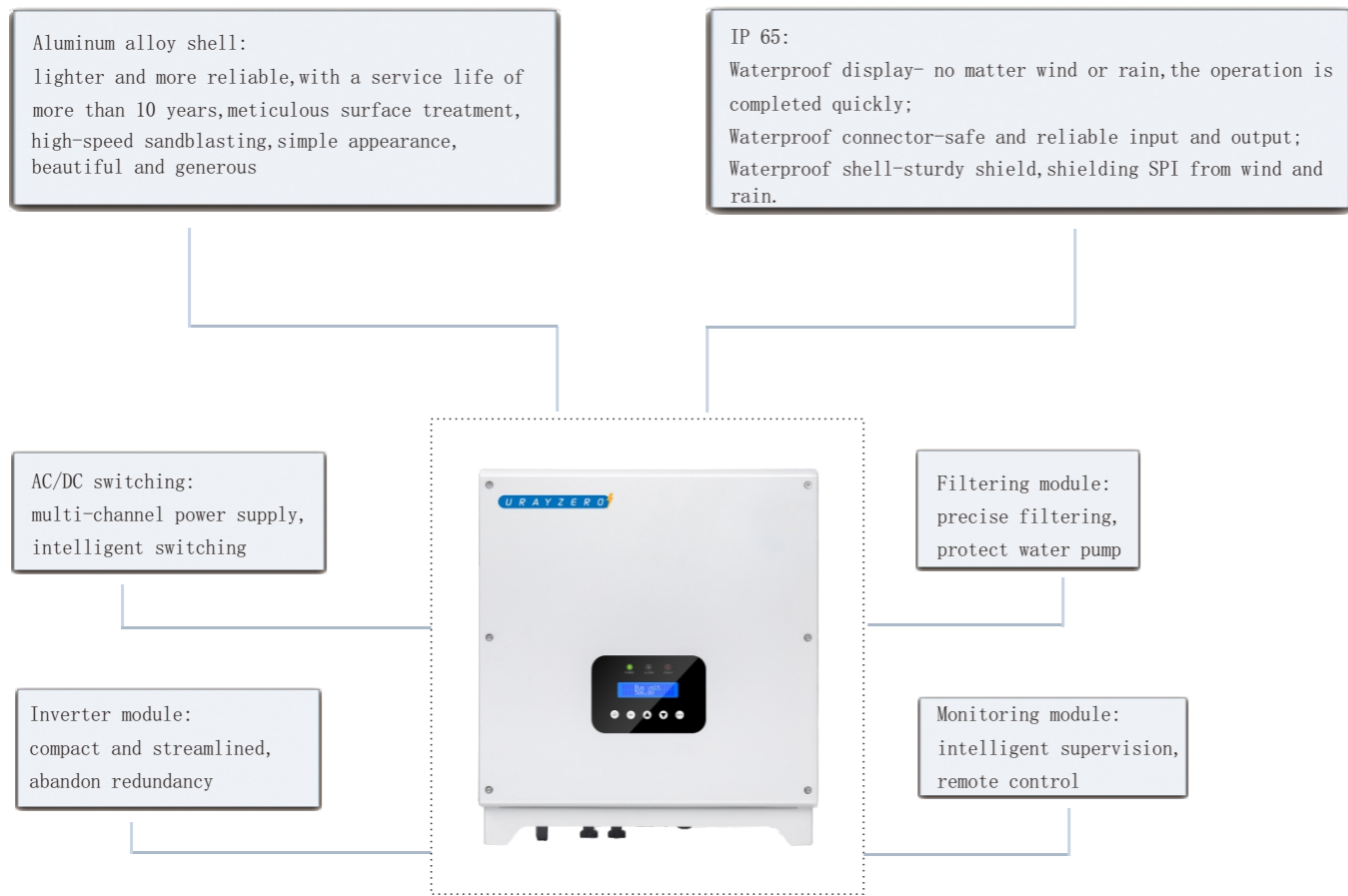

The variable frequency drive design can adjust the output frequency in real time to control the speed of the motor according to the intensity of sunlight. greatly improve efficiency, better protect water pump, and keep the maximum utilization of solar panels.

- Drive power-matched three phases AC pump
- Adopt advanced IGBT power module
- High conversion efficiency, low temperature rise, low noise, long lifespan
- Advanced MPPT technology, efficiency 99%
- Fully automatic operation, it can store operation date for 5 years
- LCD display
- Interface: RS485/Wifi/GPRS
- Comes with combiner box function, easy to install, operate and maintain
- Come with AC bypass function to get power from government grid
- Don't connect to battery, efficiently store water instead of electricity
- Perfect system protection: Over load protection, Over voltage protection, Over current protection, Under voltage protection, Reverse connection, Dry load protection, Overflow protection, Under frequency protection, Minimum start power protection, Waterproof protection

Three Phase Solar Pumping Inverter Details



Water Level Sensor

The water level sensor realizes the water level detection of the anti-drain function of the solar water pump system and the anti-overflow function of the water storage device.



- ◆ Compact and sturdy, easy to install
- ◆ Economical price, high accuracy,
- ◆ high long-term stability
- ◆ Wire material: PVC or PTFE
- ◆ Storage temperature: -25 ... + 60
- ◆ Product installation method: input type
- ◆ Protection level: IP68

Wifi Monitoring & GPRS Plug

Use the photovoltaic power station data collector to collect data from the water pump inverter, and upload it to the network server or local computer through GPRS, WIFI, etc., so that users can view relevant data on the Internet or local computer, which is convenient for power station managers and users. View and manage the operating data of photovoltaic power plants.

It allows people to monitor and manage clusters without going to the site to check the status of each water pump inverter. It is more conducive to data collection, curve generation, and data analysis. Network monitoring is more convenient for people to remotely manage and save labor costs.

Solar water pump systems are generally built on rooftops or remote areas, and on-site inspection is not very convenient. Therefore, photovoltaic monitoring helps people find and solve problems in time. Especially for network remote monitoring, managers can be notified via mobile phones, emails, etc., problems are found in the first time, and the cause of the problem can be judged by remote viewing data.



Solar Pumping System Application Field

Data from the World Resources Institute (2020) shows that global water withdrawals are mainly used for irrigation, industrial, domestic drinking water and livestock.

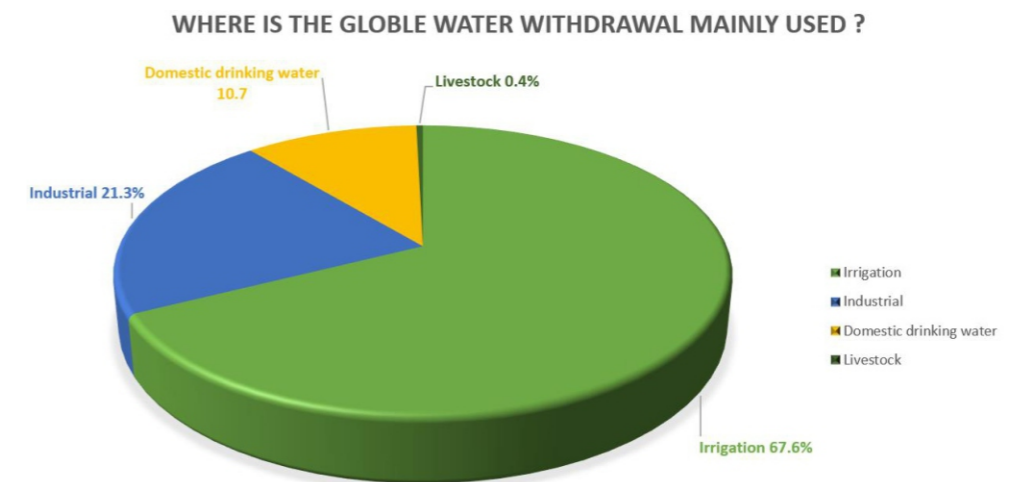

Data source: World Resource Institute 2020

Agricultural irrigation

This shows how important water is for agricultural irrigation, so the main application of solar pumping system is also for agricultural irrigation.

In times when the entire world is switching to solar, using the sun's energy in water pumping systems can significantly help and accelerate the development of agriculture in African and Middle East countries and many other poor remote areas. This concept is known as solar-powered irrigation and is used in many regions nowadays.

The truth is, solar energy might be the easiest way for farmers to produce energy, especially for those living off the electricity grids with poor infrastructure around their homes. Therefore, the use of solar water pumps in agriculture is becoming increasingly popular. The concept of solar irrigation represents a virtuous circle - when the sun shines, it feeds the irrigation system and feeds the crops which are dependant on water in sunny weather. Therefore, a large quantity of energy is being released right at the time when it is needed the most.



In addition, the solar pumping system is also suitable for the following scenarios:



Industrial water



Drinking water

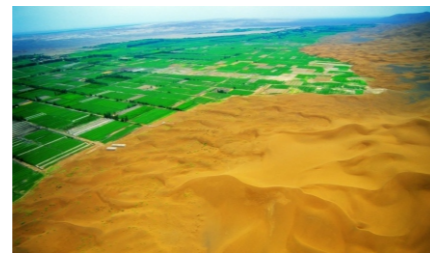

Desert governance



Sewage treatment



Oxygenate the pond



Water supply and drainage of seaside saltworks



Construct a fountain



Sprinkler irrigation



Rural water supply



Pool water supply



Desalination



Grassland pasture water

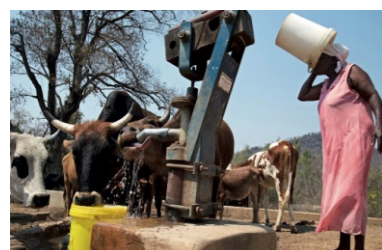

Livestock drinking water



Garden water supply

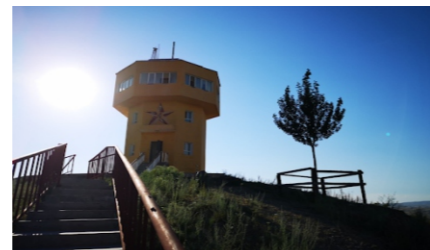

Water for border posts

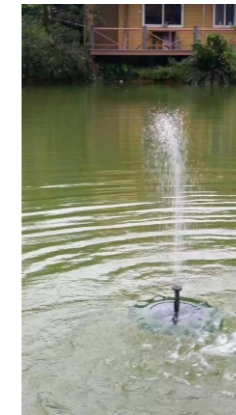

China 1.1kw Pond system



Kenya 2.2kw Pumping system



Philippines 11kw Sewage treatment



Cambodia 5.5kw Pumping system



Kenya 7.5kw Pumping system



Colombia 2.2kw Pumping system



Ethiopia 9.2kw Pumping system



Thailand 15kw Pumping system



Kenya 13kw Pumping system



Pakistan 30kw Pumping system



Egypt 45kw Pumping system



Yemen 55kw Pumping system



Yemen 75kw Pumping system